

1

2

A

A

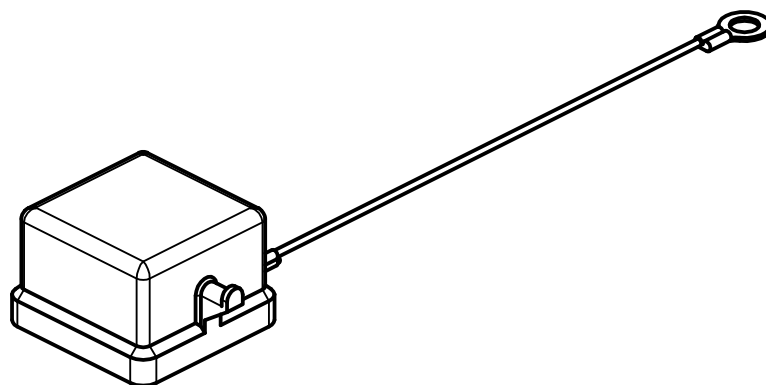

B

B

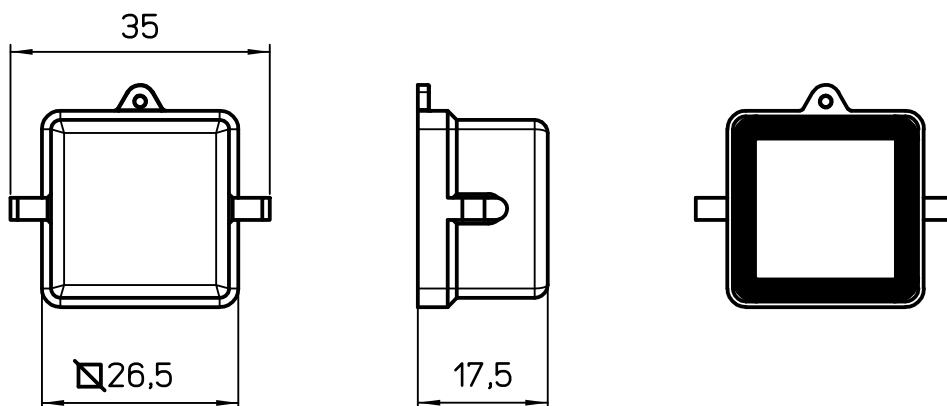

C

C

|  |  |  |  |
|--|--|--|--|
|  |  |  |  |
|  |  |  |  |
|  |  |  |  |
|  |  |  |  |

|      |      |           |  |
|------|------|-----------|--|
| REV. | DATE | SIGNATURE |  |
|------|------|-----------|--|

|  |                         |   |  |
|--|-------------------------|---|--|
|  | <b>Dimensions in mm</b> | Simplified representation with dimensions without tolerance |  |
|--|-------------------------|---|--|

|                  |  |       |  |
|------------------|--|-------|--|
| Original Size A4 | CKH 03 CS<br>Insulating cover for female inserts GASKET - HYGIENIC | Scale |  |
| Date 23/06/20    |  | 1:1   |  |
| Sign. B. Pitasi  |  |       |  |

1

2

All rights reserved

Diritti riservati