

EMS BTDIN - Universal state moduleCat. No:
F80BVS

Contents	Pages
1. Description - Use.....	2
2. Range	2
3. Overall dimensions.....	2
4. Preparation - Connection.....	2
5. General characteristics.....	8
6. System architectures.....	12
6.1 Stand-alone	12
6.1.1 with local addressing.....	12
6.1.2 with remote addressing	13
6.2 Supervised.....	14
6.2.1 with local addressing.....	14
6.2.2 with remote addressing	16
7. Compliance and approvals.....	18

EMS BT DIN - Universal state module

Cat. No:

F80BVS

1. DESCRIPTION - USE

- . Module dedicated to Energy Management System (EMS BT DIN) use.
- . Enables to display a clear indication on the status of a circuit or of an associated modular device (MCBs, RCCBs, RCBOs...) and/or power devices (e.g. ACBs, MCCBs...) via voltage-free SPST-NO contacts.
- . Equipped with DIP switches (on the side) allowing product configuration of:
 - type of information returned by the device:
 - open, closed, tripped positions of a modular or power device
 - spring state of an ACB
 - ... (see § "Module configuration")

Symbol:

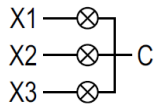

2. RANGE

- . Cat. n° F80BVS: Universal State Module; 3 inputs from voltage-free SPST-NO contact with one common terminal.

Width:

- . 1 module. 17,8 mm width.

3. OVERALL DIMENSIONS

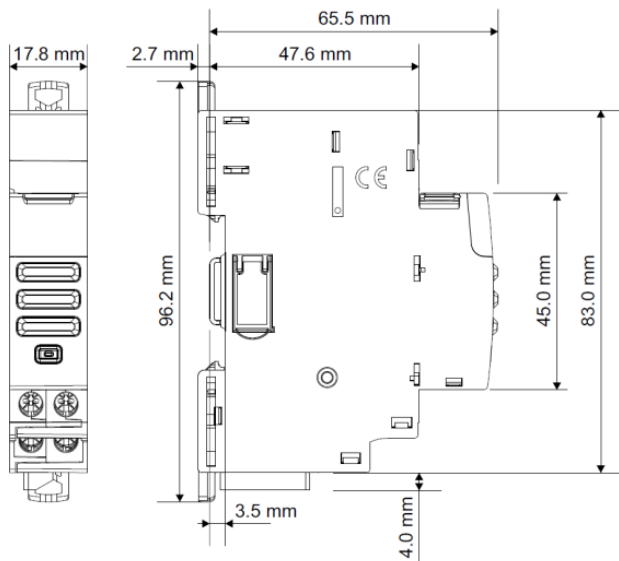

4. PREPARATION -CONNECTION

Fixing:

- . On symmetric rail EN/IEC 60715 or DIN 35 rail

Operating positions:

- . Vertical, Horizontal, Upside down, On the side



4. PREPARATION –CONNECTION (continued)

Power Supply:

- . Mandatory in 12 VDC via the specific Power supply module Cat n°F80BA
- . Two ways:
 - via specific communication patch cords (cat. nos F80BC250 /500/1000) to connect at the downstream through dedicated ports

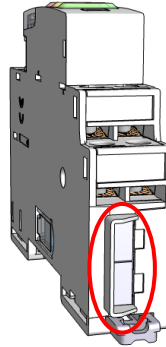

- via specific communication rails (cat. nos F80BR18/24/36) to connect at the rear through dedicated connectors

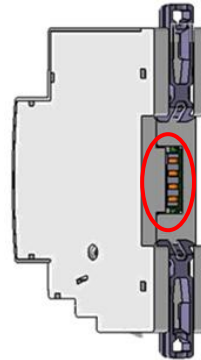

Terminals:

- . Terminal depth: 8 mm.
- . Stripping length: 8 mm

Screw head:

- . Mixed, slotted and Pozidriv n°1 (UNI7596 type Z1).

Recommended tightening torque:

- . 1 Nm.

Recommended tools:

- . For the terminals: Pozidriv n°1 or flat screwdriver 4 mm.
- . For fixing: flat screwdriver 5.5 mm (6 mm maximum).
- . For configuration DIP switches: flat screwdriver 2 mm

Conductor type:

	Copper cable	
	Without ferrule	With ferrule
Rigid Cable	1 x 0,5 mm ² to 1,5 mm ² 2 x 1,5 mm ²	-
Flexible Cable	1 x 0,5 mm ² to 1,5 mm ² 2 x 1,5 mm ²	1 x 0,5 mm ² to 1,5 mm ² 2 x 1,5 mm ²

4. PREPARATION –CONNECTION (continued)

Connection with an associated device:

. Association with an electro-mechanical MEGATIKER auxiliary contact (Cat. no M7X01) and fault contact (Cat. no M7X01) or other brand contact/fault auxiliary.

. EMS BTDIN universal state module must be configured (locally or remotely) as shown:

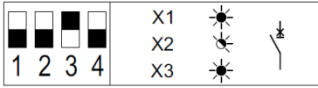

. Wiring diagram:

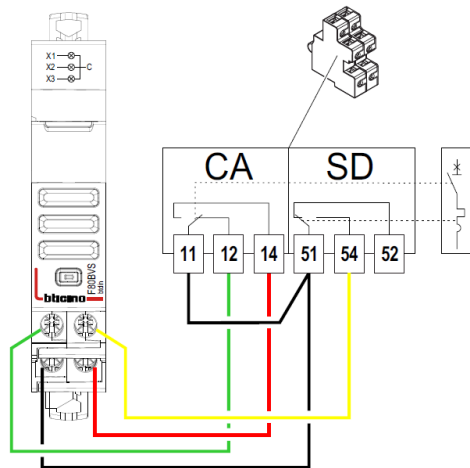

Note:

Open /Close / Tripped displayed information for a protection device. With any kind of electrical protection device (modular or power) the displayed information must be done in accordance with the handle colour status, as shown below:

“I-ON” (red) = contacts closed



“O-OFF” (green) = contacts open



Mind that the cabling of the module has also been done in this way too.

4. PREPARATION –CONNECTION (continued)

Connection with an associated device (continued):

. Association with several electro-mechanical BTDIN fault contact (Cat. no F80RC, F80CR05) or other brand fault auxiliary.

. EMS BTDIN universal state module must be configured (locally or remotely) as shown:

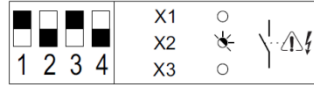

. Wiring diagram:

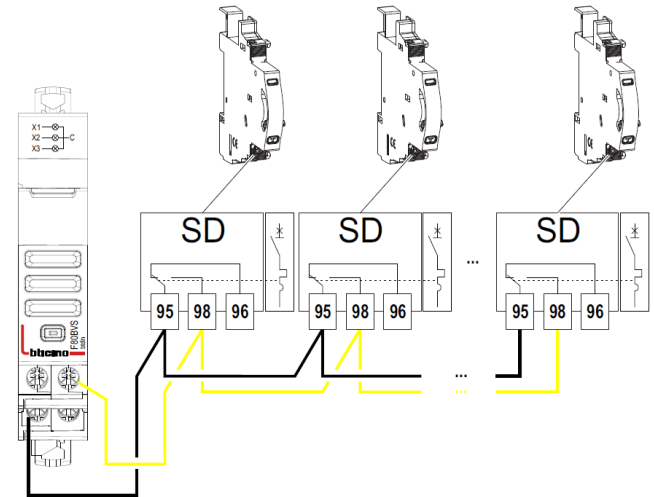

For MEGATIKER fault contact auxiliaries use terminals 51 (instead of 95) and 54 (instead of 98) of the cat. no M7X01

. Association with an electro-mechanical Contactor or Latching relay auxiliary contact (e.g. Cat. no FM1AC, FM1ACH) or other brand contact auxiliary.

. EMS BTDIN universal state module must be configured (locally or remotely) as shown:

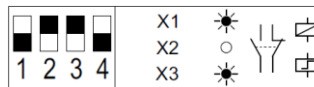

. Wiring diagram:

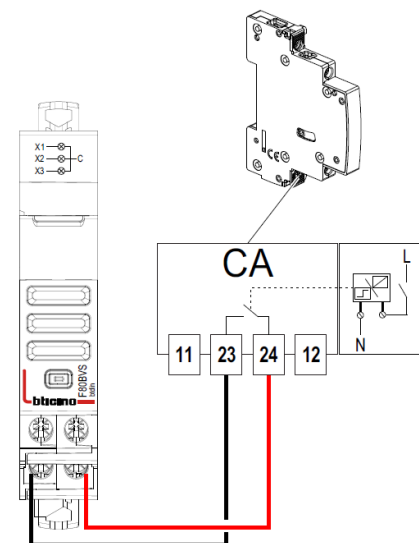

4. PREPARATION –CONNECTION (continued)

Connection with an associated device (continued):

. Association with an electro-mechanical contact "ready to close" with charged springs for MEGABREAK (e.g. Cat. no M8PC) or other brand auxiliary.

. EMS BTDIN universal state module must be configured (locally or remotely) as shown:

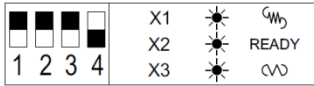

. Wiring diagram:

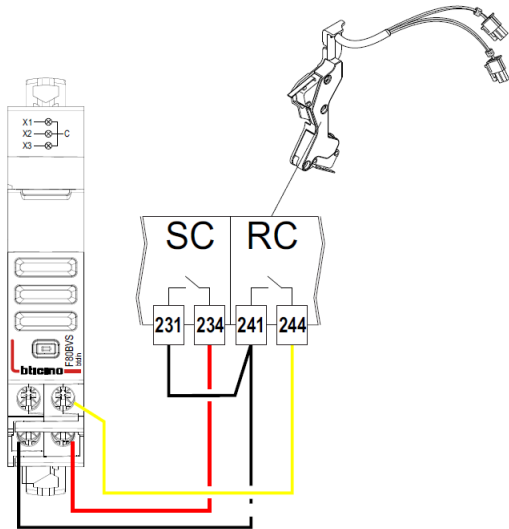

. Association with an electro-mechanical Signalling contact for MEGATIKER or MEGABREAK draw-out version (e.g. Cat. no M8POS for MEGABREAK / M7B10 for MEGATIKER) or other brand auxiliary.

. EMS BTDIN universal state module must be configured (locally or remotely) as shown:

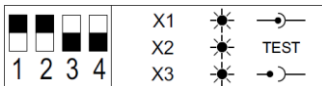

. Wiring diagram for M8POS:

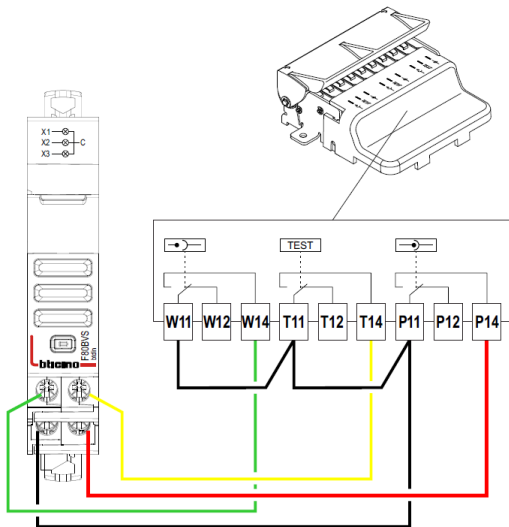

4. PREPARATION –CONNECTION (continued)

Module configuration (continued):

Note 2:

SLAVE = Repeat function

. This configuration allows you to use an EMS BTDIN universal state module (cat. no F80BVS) as Slave of an 1/2 state module (cat. no F80BCR) or of another EMS BTDIN universal state module (cat. no F80BVS) Master.

. Slave module, receives via EMS bus and repeats the signalizations of the master module through 3 frontal led.

. No need to wire the terminals of the slave module

. **Slave module must have the same address of the Master module**

. **Example**, EMS BTDIN Universal state module used as slave of an 1/2 state module

. EMS BTDIN universal state "Slave" module must be configured (locally or remotely) as shown:

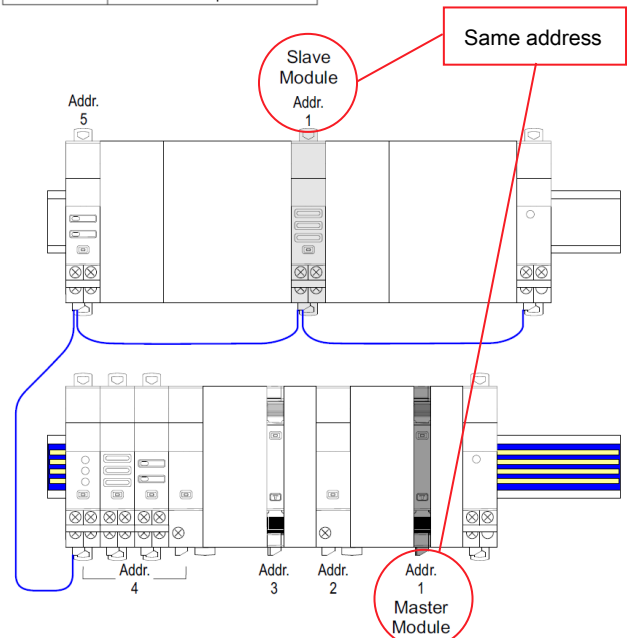
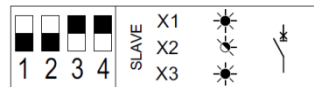

4. PREPARATION –CONNECTION *(continued)*

Data connection (EMS BT DIN modules inter-connection):

. Via specific communication patch cords (cat. nos F80BC250/500/1000)



Allow data transmission between the different EMS BT DIN modules. This type of connection is recommended when there are few EMS BT DIN modules, distributed all over the enclosure.

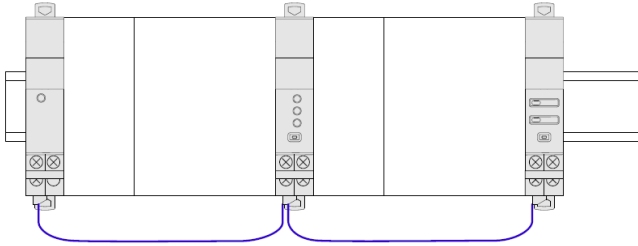

Implementing: with this configuration, the plastic protection cover of the backside communication ports on the EMS BT DIN module must be kept on.

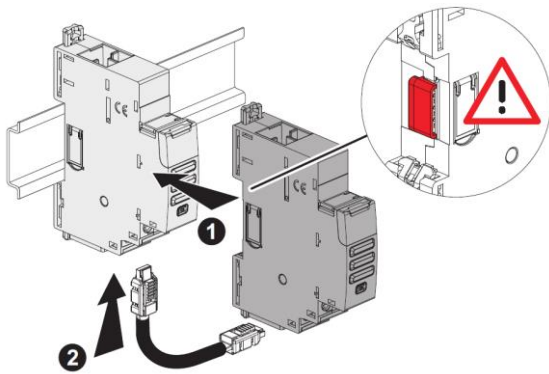

4. PREPARATION –CONNECTION *(continued)*

Data connection (EMS BT DIN modules inter-connection)

(continued):

. Via specific communication rails (cat. nos F80BR18/24/36).



. Allow data transmission between the different EMS BT DIN modules.

This type of connection is recommended when there are several EMS BT DIN modules on the same DIN row.

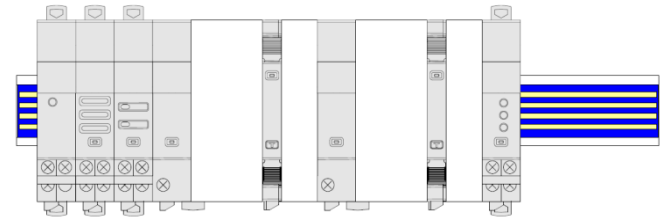

Implementing: with this configuration, the plastic protection cover of the backside communication ports on the EMS BT DIN module must be removed.

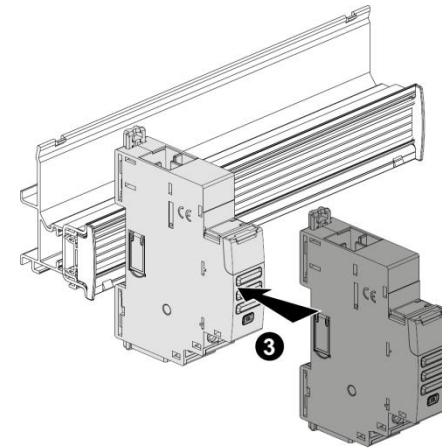
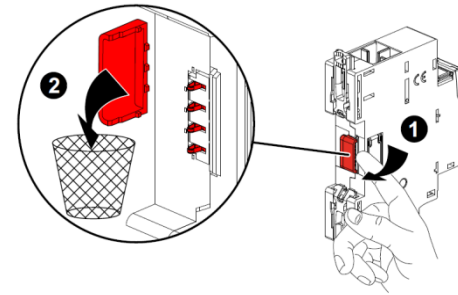

4. PREPARATION –CONNECTION *(continued)*

Data connection (EMS BT DIN modules inter-connection)

(continued):

. Via a mix between specific communication patch cords and communication rails in order to create a link between several rows

Two situations:

- Individually connected with communication rails.
The communication patch cord allows to connect two rows.



- Individually connected with communication patch cords & communication rail.
The communication patch cords allow to connect EMS BT DIN module on a row and to connect two rows.

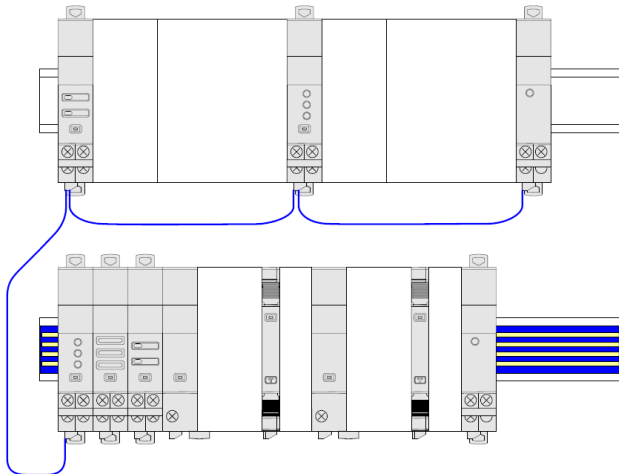

Labelling:

. Circuit identification by way of a label inserted in the label holder situated on the front of the product.

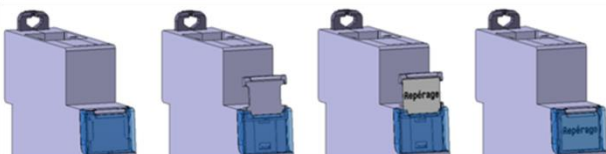

4. PREPARATION –CONNECTION *(continued)*

Position in a row:

. The product profile and the position of the terminals at the downstream allow the insertion of the prong-busbar by the upstream. In this way the position of the EMS BT DIN device in a row can be freely chosen

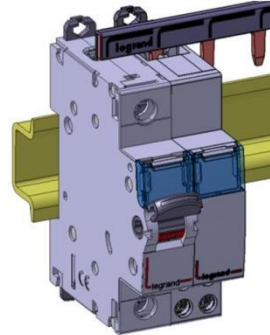

Module maintenance:

. A device may be replaced in the middle of a row supplied with prong-busbar without disconnecting the other devices.

1. Put the clamp in the unlocking position

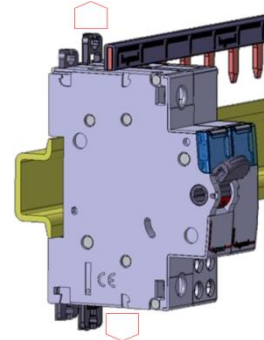

1. Put the clamp in the unlocking position

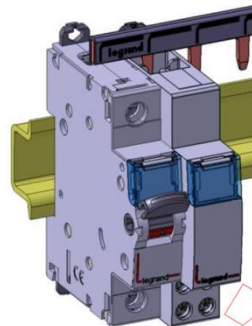

2. Pull the device forward in order to release it from the rail

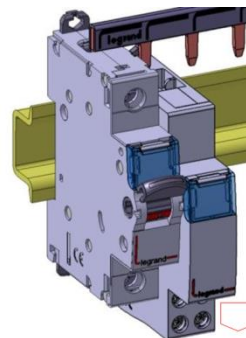

3. Pull the device downward in order to release it completely from the prongs of the busbar

5. GENERAL CHARACTERISTICS

Front face marking:

. By permanent ink pad printing (red line) and laser marking

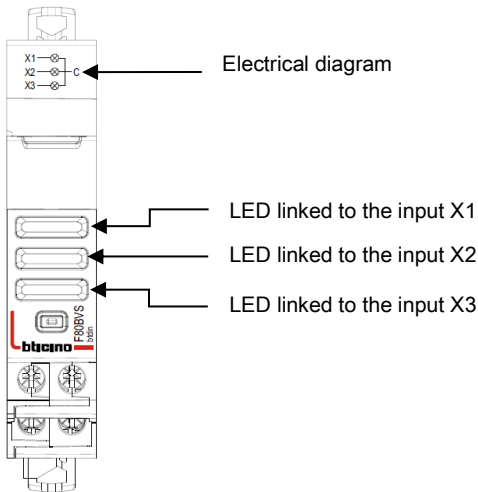

Lateral side marking:

. By laser.

left side: Standard and programming information

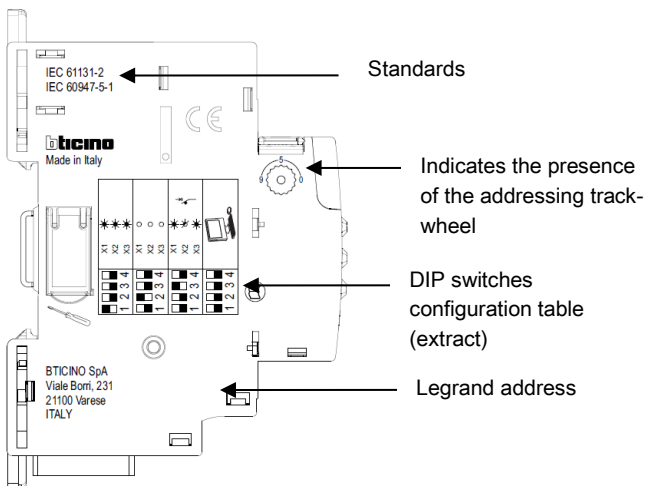

right side: cabling and traceability information

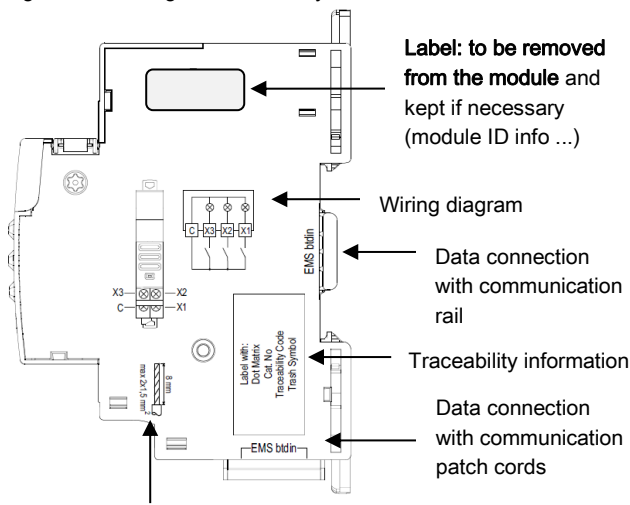

Cabling information

5. GENERAL CHARACTERISTICS (continued)

Signalling LEDs:

. Equipped with configurable signalling LEDs: red, yellow and green (see § "Module configuration"):

- LED turned on: indicates that the corresponding inputs is high (contact cabled between the common terminal "C" and the corresponding terminal "X1", "X2", or "X3" is closed)
- LED turned off: indicates that the corresponding inputs is low (contact cabled between the common terminal "C" and the corresponding terminal "X1", "X2", or "X3" is open)

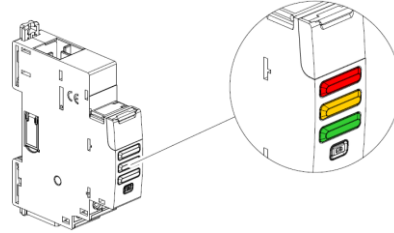

. Technology: non-replaceable LED lamps

. Life time 100 000 hours without maintenance.

. The ergonomic design of the translucent plastic window allows a homogeneous projection of the light.

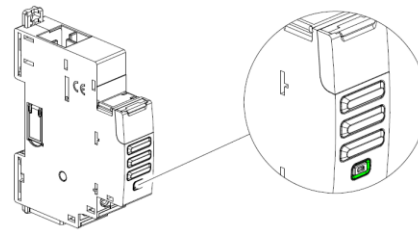

Multi-Functions button:

. Front face button as several functions:



. Gives information about the operating state on the module

Possible states:

Colour	State	Meaning
 red	Slow blinking	Error (e.g. addressing error)
	Fast blinking	No function
	Steady (pressing the multifunction button longer than 10 sec.)	Total reset [any firmware updates are preserved]
 green	Slow blinking	System process is running. Wait until the Led turns steady
	Fast blinking (pressing the multifunction button for 5 sec.)	put in "Stand-by" the EMS module (no remote action and communication available)
	Steady	System OK, connection is running
 orange	Slow blinking	Creation of a link with "Link Functionality" procedure (see next §)
	Fast blinking	Device's firmware update in progress
	Steady	No function

5. GENERAL CHARACTERISTICS *(continued)*

Link Functionality:

. This function allows you to link two EMS BT DIN modules to create automatic actions that, once programmed, can run independently without a connection to a manager is needed.

The basic rule is the link between an event (circuit breaker that trip, a threshold exceeded, etc.) and an action accordingly (signalling, opening of a circuit by motorized control or contactor, etc.).

Possible associations are:

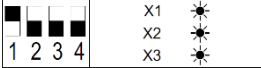
Event generator	Action module		
	Command: F80BC	State + Command: F80BCS	State: F80BV
Measure: F80BM3M63, F80BMM63, F80BMT63, F80BMT125, F80BMT, F80BMR630, F80BMR1600, F80BMR3200, F80BMR6300	✓	✓	✓ Only with the module configured (locally or remotely) as shown: 
State: F80BCR, F80BVS	✓	✓	✗ It's enough to configure the module (locally or remotely) as "Slave"
State + Command: F80BCS	✓	✓	✗ It's enough to configure the module (locally or remotely) as "Slave"

Note:

- association can only be of type 1 to 1 (1 event and 1 action).
- modules already associated cannot be used for other associations.
- all the configuring procedure will be done with the Configuration Software (available online for free). *[For more details refer to the Installation Manual of EMS BT DIN Configuration software]*

5. GENERAL CHARACTERISTICS *(continued)*

Modules compatible with "Link Functionality" feature: firmware versions and production date:

Cat n°	Firmware version	Production date indicated on the label stucked on the side of the module
F80BM3M63	all firmware versions	any production date
F80BMM63	ver. ≥ 2.0.1	date ≥ 18W25
F80BMT63	ver. ≥ 2.0.1	date ≥ 18W49
F80BMT125	all firmware versions	any production date
F80BMT	ver. ≥ 2.0.1	date ≥ 18W35
F80BMR630	all firmware versions	any production date
F80BMR1600	all firmware versions	any production date
F80BMR3200	all firmware versions	any production date
F80BMR6300	all firmware versions	any production date
F80BCR	ver. ≥ 2.0.1	date ≥ 18W47
F80BVS	ver. ≥ 2.0.2	date ≥ 18W35
F80BCS	ver. ≥ 2.0.6	date ≥ 18W45
F80BC	ver. ≥ 3.0.2	date ≥ 18W39
F80BV	ver. ≥ 2.0.4	date ≥ 18W38
F80BIM1	ver. ≥ 3.0.8	date ≥ 18W34

Insulation voltage:

. $U_i = 400 \text{ V}$

Impulse withstand voltage U_{imp} :

. EMS ports / Input terminals:

wave 1,2 / 50 μs : 6 kV

alternate current 50 Hz / 1 min.: 3 kV

Pollution degree:

. 2 according to IEC/EN 60898-1.

Overvoltage category:

. III

Dielectric strength:

. 2500 V

Plastic material:

. Self-extinguishing polycarbonate.

. Heat and fire resistant according to IEC/EN 60695-2-12, glow-wire test at 960°C.

. Classification UL 94 / IECEN 60695-11-10: V1

Ambient operating temperature:

. Min. = -25°C. Max. = +70°C

Ambient storage temperature:

. Min. = -40°C. Max. = +70°C

5. GENERAL CHARACTERISTICS *(continued)*

Protection Index:

- . Protection index of terminals against direct contacts: IP2X (IEC/EN 60529).
- . Protection index of terminals against solid and liquid bodies (wired device): IP 20 (IEC/EN 60529).
- . Protection index of the front face against solid and liquid bodies: IP 40 (IEC/EN 60529).
- . Class II, front panel with faceplate.

Average weight per device:

- . 0,055 kg.

Volume when packed:

- . 0,21 dm³.

Consumption:

- . Values at 12 VDC

Configuration	W	mA
Stand-by	0,258	21,5
All led OFF	0,258	21,5
1 led ON	0,298	24,8
2 led ON	0,337	28,1
All led ON	0,376	31,4

6. SYSTEM ARCHITECTURES

The EMS BTDIN is a polyvalent system and, according to the needs of the customer, can be set up and/or used as “Stand-alone” or “Supervised” system. Based on this choice the configuration and addressing methods are different.

Four possible architectures are provided:

6.1 Stand-alone system

6.1.1 with local addressing (through the track wheel)

6.1.2 with remote addressing (through a computer)

6.2 Supervised (Computer Supervisory System)

6.2.1 with local addressing

6.2.2 with remote addressing

6.1 Stand-alone system

. **Stand-alone** = autonomous system. To be used by the end-user if it is not necessary to have a computer for the supervision outside the envelope. Everything can be managed on site.

6.1.1 Stand-alone system with local addressing (through the track wheel)

Local addressing advantages:

- No configuration software needed to set-up the installation
- **It is not necessary to use a computer to manage settings** (configurations, test, ...) and to use the system (visualize and be alerted, ...). Everything can be done through the Mini configuration module (local display, cat. no F80BV). [Refer to the technical sheet dedicated to this module for details].
- No communication Interfaces or gateways are required.
- Installation can be done without the intervention of a System Integrator

Programming procedure:

. For EMS BTDIN modules which need some: mandatory through the lateral DIP-switches of each EMS BTDIN module (see § “Module configuration”)

Addressing procedure:

. For all EMS BTDIN modules: mandatory through the track wheel located on the top upper face of each EMS BTDIN modules

. Marked from 0 to 9 in order to locally define the Modbus address of the EMS BTDIN modules

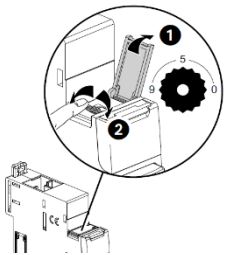

Note for Measure Module “3x single phase”:

This module is to be consider as 3 modules with 3 different Modbus Address. The module takes automatically the two addresses immediately following to the programmed one (e.g. Programmed address = 12, Addresses of the module 12, 13, 14)

Consequences of the local addressing mode (through the track wheel):

- . Each device of the system must be addressed.
- . Addresses available: from 1 to 9
- . Address 0 not permitted
- . It is possible to assign to several devices the same address with the purpose of grouping different functions, **because they are related to the same electrical circuit**. For example, it is possible to assign the same address to a signalling auxiliary module (cat. no F80BCR), a universal control module (cat. no F80BC), a measuring module, and so on. In this way on the EMS BTDIN mini configuration module (local display) the grouped function will be displayed as a unique “device” with all grouped functions. [Refer to the schemes hereunder]

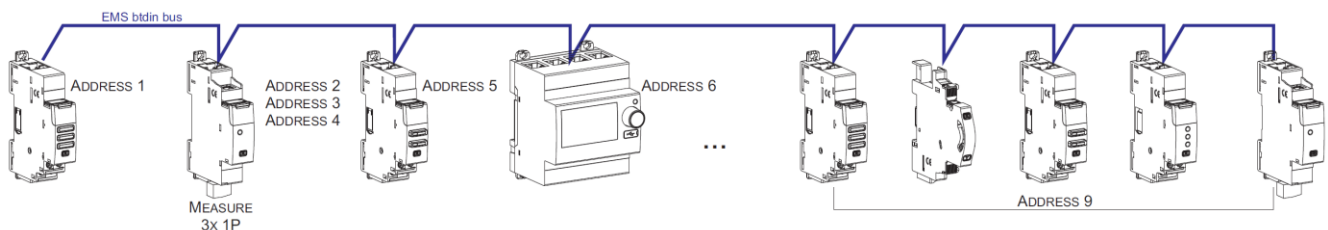

Note for the mini configuration module (local display)

- . It is possible to assign it the same address as another EMS BTDIN through the programming menu of the device
- . The mini configuration module can be placed everywhere in the EMS BTDIN bus

6. SYSTEM ARCHITECTURES

6.1 Stand-alone system *(continued)*

6.1.2 Stand-alone system with remote addressing (through a computer)

Remote addressing advantages:

- Whole configuration (addresses and functions) can be set up through the EMS Configuration software
- Configuration software available for free
- **Automatic detection of the EMS BT DIN modules** installed in the system (characteristics, functions, configuration...)
- **Increased settings possibilities: load shedding function**
- Increased addressing: **up to 30 Modbus addresses in a system**

Programming procedure:

. For EMS BT DIN modules which need some: mandatory through the lateral DIP-switches of each EMS BT DIN module or via the configuration software *(see § "Module configuration")*

Addressing procedure:

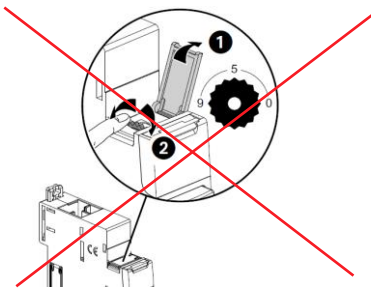

The track wheel must be left in position "0".

. It is not necessary to address the EMS BT DIN modules. **The track wheel must be left in default position "0".**

. All the addressing/configuring procedure will be done with the Configuration Software (available online for free)

. With remote addressing, the software does the automatic detection of modules installed in the system, but the supervision is not possible until the users assign the remote address and all the characteristics to each module.

Note: it is mandatory to connect the computer to the mini configuration module with an USB-micro USB cable. *[For more details, refer to the technical data sheet of the Mini configuration module EMS BT DIN]*

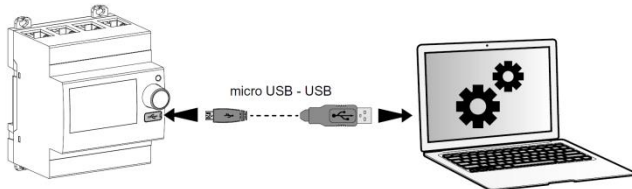

Read configuration from USB

Found:
8 modules
8 groups

Group modules in sets assigning the same address.
Press "Continue" to save addressing and import configuration.

Found modules				
	Model	Module ID	Address	Result
	F80BIM1	EMS-IR485 interface	FFFF-FFFF-FFFF-FC0C	+ 1 ✓
	F80BCR	State (modular device)	FFFF-FFFF-FFFF-FFFF	+ 2 ✓
	F80BVS	State (generic)	FFFF-FFFF-FFFF-F09B	+ 4 ✓
	F80BCS	Control + State (CT/LR)	FFFF-FFFF-FFFF-FCFC	+ 4 ✓
	F80BC	Control (generic)	FFFF-FFFF-FFFF-F051	+ 2 ✓
	F80BMM3	Measure (singlephase 0.5A)	FFFF-FFFF-FFFF-F068	+ 2 ✓
	F80BMT3	Measure (threephase 0.5A)	FFFF-FFFF-FFFF-F06D	+ 4 ✓
	F80BI	Measure (cube)	FFFF-FFFF-FFFF-F088	+ 5 ✓
	F80BMT	Measure (CT)	FFFF-FFFF-FFFF-F071	+ 3 ✓

Click on this icon on the table to make the LED blink on the corresponding module.

Rotary addr. Refresh Continue

bticino

Note for Measure Module "3x single phase":

This module is to be consider as 3 modules with 3 different Modbus Address. The module takes automatically the two addresses immediately following to the programmed one (e.g. Programmed address = 2, Addresses of the module 2, 3, 4)

6. SYSTEM ARCHITECTURES

6.1 Stand-alone system (continued):

6.1.2 Stand-alone system with remote addressing (through a computer) (continued):

Consequences for the system architecture:

- for 1 mini configuration module (cat. no F80BV)
 - o up to **30 EMS BTDIN modules** (e.g. 30 devices grouped per functions with addresses from 1 to 30)

It is possible to assign to several devices the same address with the purpose of grouping different functions, **because they are related to the same electrical circuit**. For example, it is possible to assign the same address to a signalling auxiliary module (cat. no F80BCR), a universal control module (cat. no F80BC), a measuring module, and so on. In this way on the EMS BTDIN display or in a supervision system the grouped function will be displayed as a unique “device” with all grouped functions. [Refer to the schemes here under]

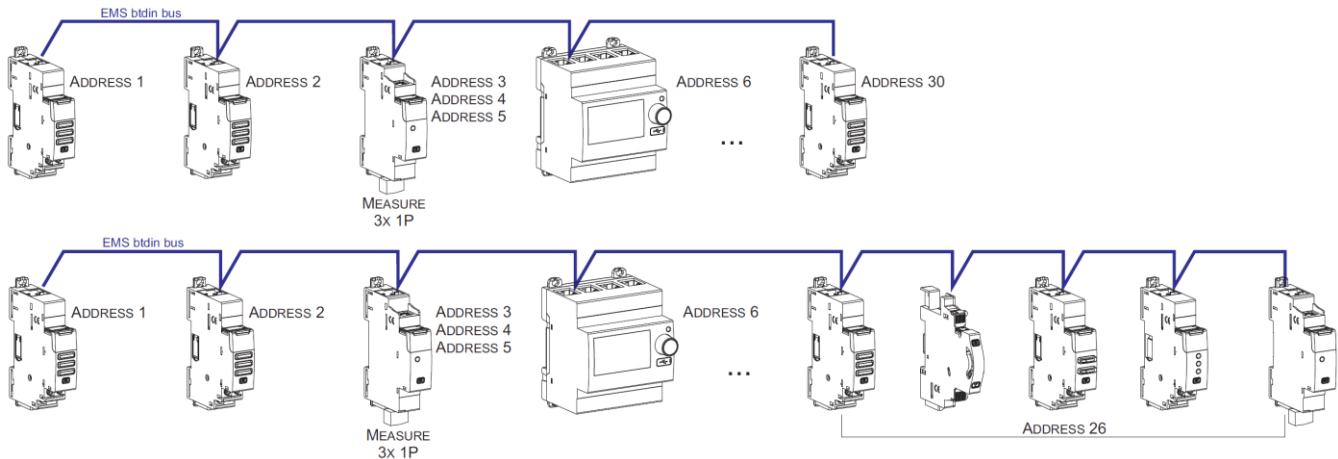

Note for the mini configuration module (local display)

- . It is possible to assign it the same address as another EMS BTDIN
- . The mini configuration module can be placed everywhere in the EMS BTDIN bus

6.2 Supervised system (Computer Supervisory System)

. **Supervised system** = System to be used through a Computer Supervisory System to remotely read data from the EMS BTDIN devices and/or do operations on these devices (e.g. commands of a motor driven or contactor ...).

6.2.1 Supervised system-with local addressing (through the track wheel)

Local addressing advantages:

- No configuration software needed to set-up the installation
- Installation can be done without the intervention of a System Integrator

Programming procedure:

. For EMS BTDIN modules which need some: mandatory through the lateral DIP-switches of each EMS BTDIN module (see § "Module configuration")

Addressing procedure:

- . For all EMS BTDIN modules: mandatory through the track wheel located on the top upper face of each EMS BTDIN modules
 - . Marked from 0 to 9 in order to locally define the Modbus address to EMS BTDIN modules
- In this system the Modbus address of an EMS BTDIN module device or group of modules (several functions) is obtained considering the address of the interface Modbus/EMS BTDIN Interface as tenth and the address of a device or group of function as unit (e.g. Interface address 1 = 10 → address of module n°5 = Modbus address 15)



Note for Measure Module “3x single phase”:

This module is to be consider as 3 modules with 3 different Modbus Address. The module takes automatically the two addresses immediately following to the programmed one (e.g. Programmed address = 12, Addresses of the module 12, 13, 14)

6. SYSTEM ARCHITECTURES *(continued)*

6.2 Supervised system (Computer Supervisory System) *(continued)*

6.2.1 Supervised system-with local addressing (through the track wheel) *(continued)*

Consequences of the local addressing mode (through the track wheel):

- . Each device of the system must be addressed.
- . Addresses available: from 1 to 9
- . Address 0 not permitted

It is possible to assign to several devices the same address with the purpose of grouping different functions, **because they are related to the same electrical circuit**. For example, it is possible to assign the same address to a signalling auxiliary module (cat. no F80BCR), a universal control module (cat. no F80BC), a measuring module, and so on. In this way on the EMS BTDIN display or in a supervision system the grouped function will be displayed as a unique "device" with all grouped functions. *[Refer to the scheme hereunder]*

Note: In this configuration the Modbus address of an EMS BTDIN module device or group of modules (several functions) is obtained considering the address of the interface Modbus/EMS BTDIN Interface as tenth and the address of a device or group of function as unit (e.g. Interface address 1 = 10 and device address = 5 → Modbus address = 15)

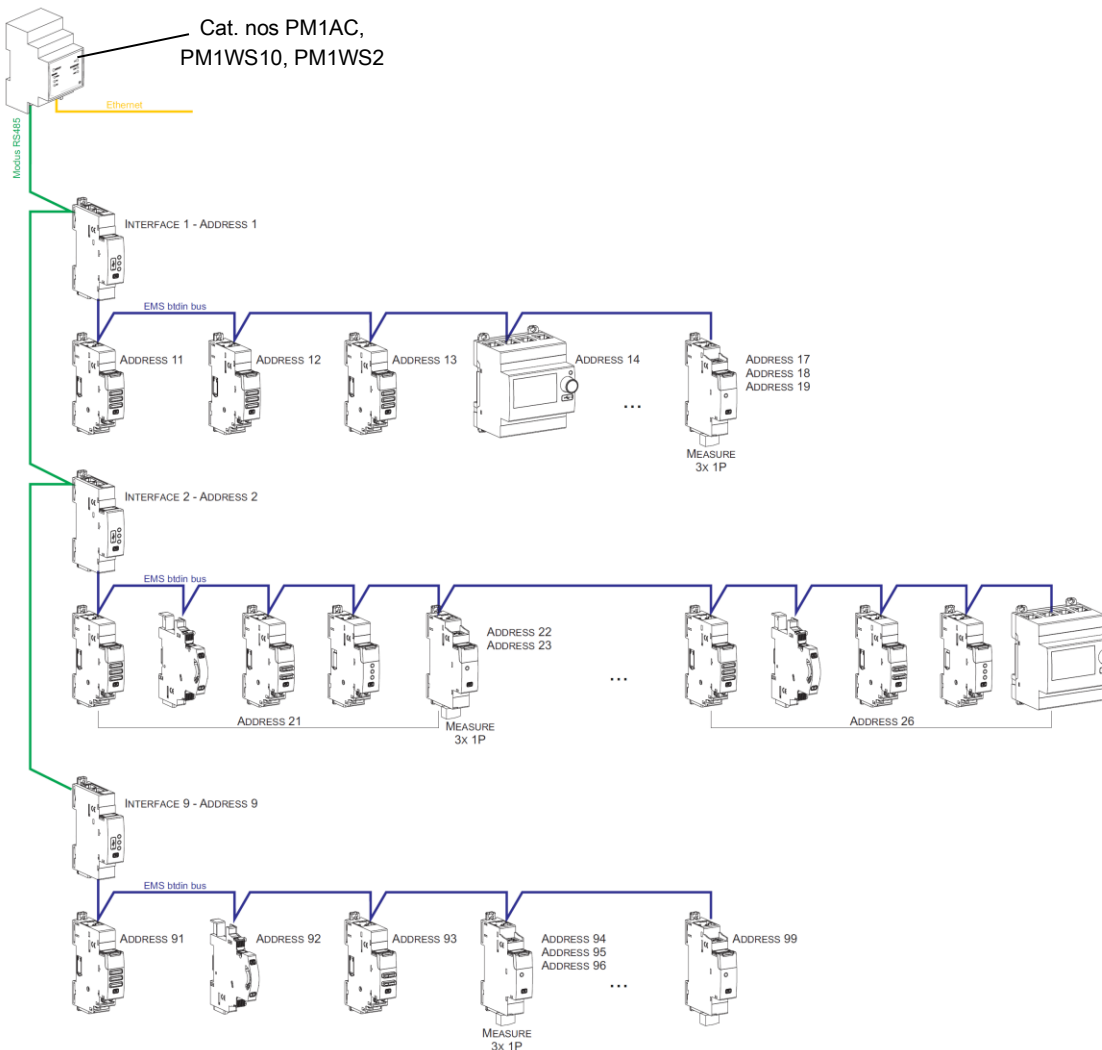

Consequences for the system architecture:

- for 1 IP/Modbus gateway (cat. no PM1AC):
 - o up to **81 Modbus address**
 - o mandatory limit of max. **9 Modbus/EMS BTDIN interfaces** or max. **1000 m of Modbus cable** (cable Belden 9842, Belden 3106A or equivalent) or max. **50 m of Category 6 cable** (FTP or UTP).
- for 1 Modbus/EMS BTDIN Interface (cat. no F80BIM1):
 - o up to **30 EMS BTDIN modules** (ex. 30 devices grouped per functions with addresses from 1 to 9)

Note: with local addressing, the Modbus/EMS BTDIN interface, does the automatic detection of modules (characteristics, functions, configuration...)

6. SYSTEM ARCHITECTURES *(continued)*

6.2 Supervised system (Computer Supervisory System) *(continued)*

6.2.2 Supervised system-with remote addressing (through a computer)

Remote addressing advantages:

- Whole of configuration (addresses and functions) can be done a remotely through the EMS Configuration software
- Configuration software available for free
- **Automatic detection of the EMS BT DIN modules** installed in the system (characteristics, functions, configuration...)
- **Increased settings possibilities: load shedding function**
- Increased addressing: **up to 32 Modbus/EMS BT DIN interfaces**
- Increased addressing: **up to 247 Modbus addresses in a system**

Programming procedure:

. For EMS BT DIN modules which need some: mandatory through the lateral DIP-switches of each EMS BT DIN module or via the configuration software (see § "Module configuration")

Addressing procedure:

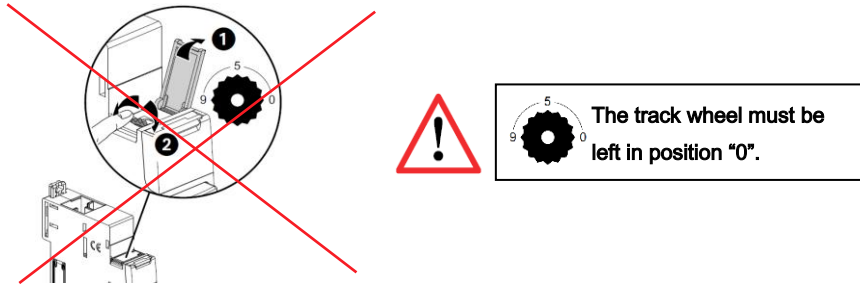

. It is not necessary to address the EMS BT DIN modules. **The track wheel must be left in default position "0".**

. All the addressing/configuring procedure will be done with the Configuration Software (available online for free)

. With remote addressing, the software does the automatic detection of modules installed in the system, but the supervision is not possible until the user assigns the remote address and all the characteristics to each module.

Note: it is mandatory to connect the computer to the different Modbus/EMS BT DIN interface with an USB-micro USB cable (one interface at a time). [For more details, refer to the technical data sheet of the Modbus/EMS BT DIN interface]

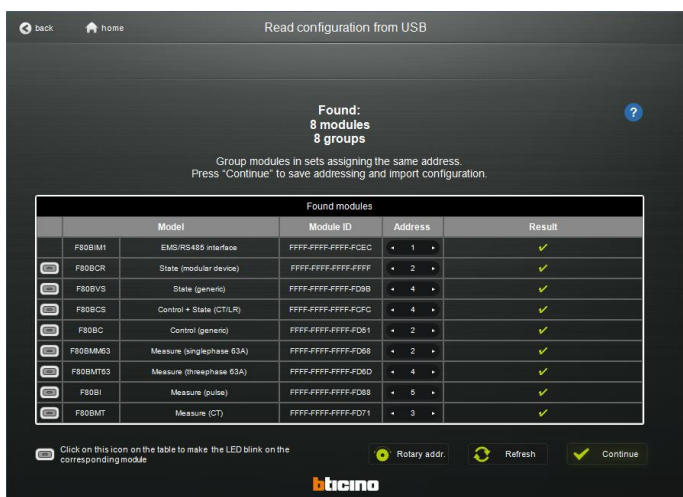
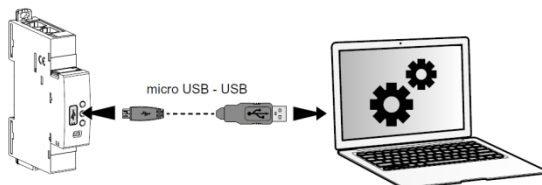

Note for Measure Module "3x single phase":

This module is to be consider as 3 modules with 3 different Modbus Address. The module takes automatically the two addresses immediately following to the programmed one (e.g. Programmed address = 2, Addresses of the module 2, 3, 4)

6. SYSTEM ARCHITECTURES *(continued)*

6.2 Supervised system (Computer Supervisory System) *(continued)*

6.2.2 Supervised system-with remote addressing (through a computer) *(continued)*

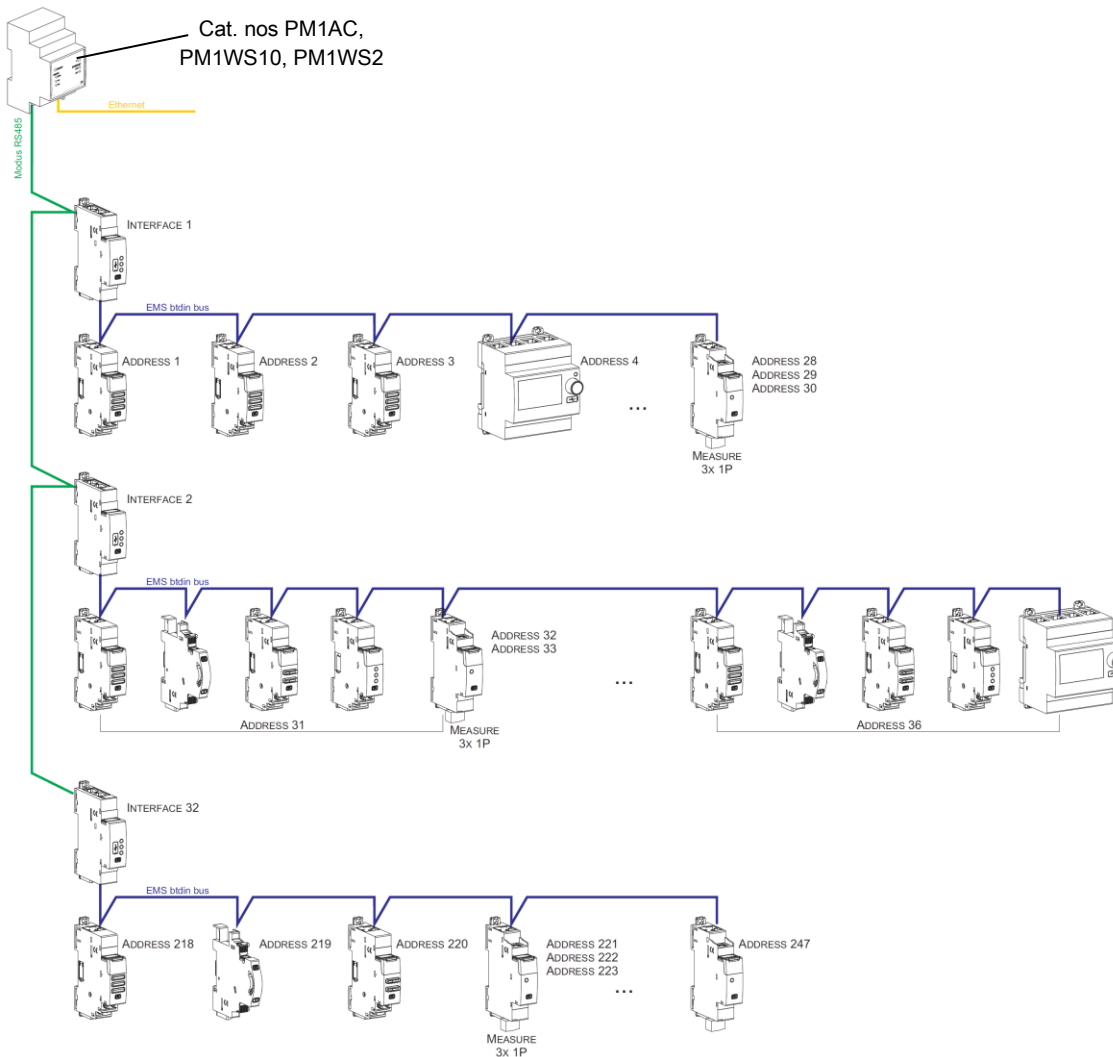

Consequences for the system architecture:

- for 1 IP/Modbus gateway (cat. no PM1AC):
 - o up to **247 Modbus address**
 - o Because of Modbus: mandatory limit of max. **32 Modbus/EMS BTDIN interfaces** or max. **1000 m of Modbus cable** (cable Belden 9842, Belden 3106A or equivalent) or max. **50 m of Category 6 cable** (FTP or UTP).
- for 1 Modbus/EMS BTDIN Interface (cat. no F80BIM1):
 - o up to **30 EMS BTDIN modules** (e.g. 30 devices grouped per functions with addresses from 1 to 30)

It is possible to assign to several devices the same address with the purpose of grouping different functions, **because they are related to the same electrical circuit**. For example, it is possible to assign the same address to a signalling auxiliary module (cat. no F80BCR), a universal control module (cat. no F80BC), a measuring module, and so on. In this way on the EMS BTDIN display or in a supervision system the grouped function will be displayed as a unique “device” with all grouped functions. *[Refer to the scheme up here]*

7. COMPLIANCE AND APPROVALS

Compliance to standards:

- . Compliance with Directive on electromagnetic compatibility (EMC) n° 2014/30/EU
- . Compliance with low voltage directive n° 2014/35/EU.
- . Electromagnetic Compatibility:
 - IEC/EN 61131-2
 - IEC/EN 60947-5-1

Environment respect - Compliance with EU directives:

- . Compliance with Directive 2011/65/EU as amended by Directive 2015/863 (RoHS 2) on the restriction of the use of certain hazardous substances in electrical and electronic equipment.
- . Compliance with REACH regulation (1907/2006): at the date of the publication of this document no element of the SVHC substance list (updated on 27/06/2018) is present in these products.
- . WEEE directive (2012/19/EU): the sale of this product is subject to a contribution to eco-organisations in each country responsible for managing end-of-life products in the field of application of the European Waste Electronic and Electrical Equipment Directive.

Plastic materials:

- . Halogens-free plastic materials.
- . Marking of parts according to ISO 11469 and ISO 1043.

Packaging:

- . Design and manufacture of packaging compliant to decree 98-638 of the 20/07/98 and also to directive 94/62/CE.

Environmental profile:

- . PEP document available