

SISTEMI PER CARICHI PESANTI WEIGHING LOADS SYSTEMS

SISTEMA STANDARD / STANDARD SYSTEM

Mensola - MP Bracket - MP

In acciaio zincato a caldo per immersione dopo lavorazione (CEI 7.6) (ZF).
Per fissaggi a parete o su profilati **PSP - PRP - PRL - PRM**.
Asole sul piano d'appoggio 7 x 20 mm.
Piastra d'ancoraggio con foro Ø 11 mm e asola 11 x 17 mm;
le mensole B 110 e B 160 hanno solo un'asola 9 x 16 mm, in centro alla piastra.

In hot galvanized steel after machining (CEI 7.6) (ZF).
For wall mounting or on **PSP - PRP - PRL - PRM**.
Slots 7 x 20 mm on supporting surface.
Mounting plate with hole Ø 11 mm and slot 11 x 17 mm;
the B 110 and B 160 brackets only with one slot 9 x 16 mm on the center.



A

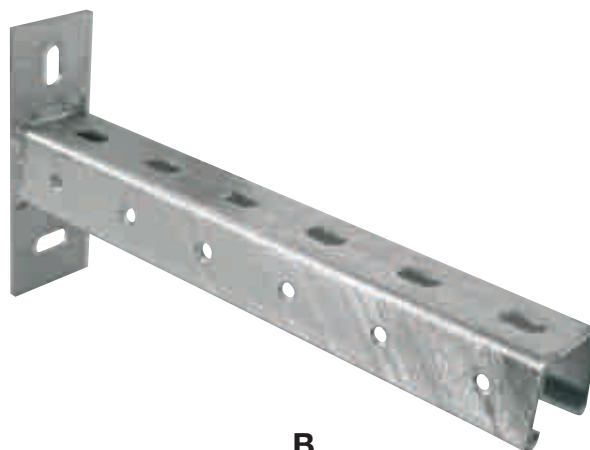

B



A norme CEI EN 50085-1, 50085-2-1 / CEI EN Standard 50085-1, 50085-2-1
Conforme CEI EN 61537 / In according to CEI EN 61537

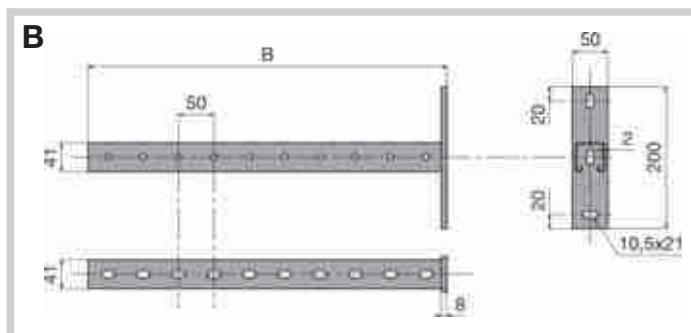
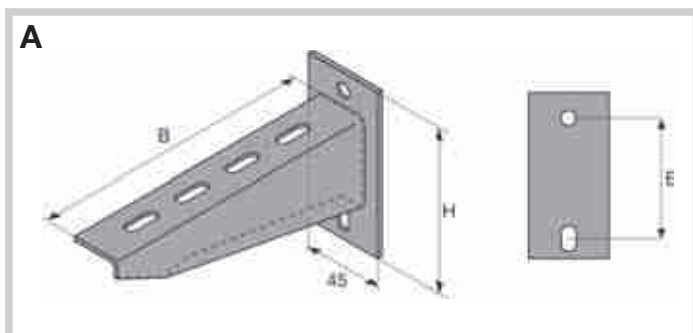

Tipo Type	Base Base B	Codice Code ZF	Portata Load cap.		Altezza Height H	Interasse (mm) Wheelbase E		kg/pz kg/pcs	Conf.pz Pack.pcs
			N	kgf		E	E		
A	110	2510301	1.470	150	54	-	0,130	30	
A	160	2510302	1.470	150	54	-	0,210	30	
A	220	2510303	1.325	135	105	75	0,360	40	
A	320	2510304	2.530	258	135	105	0,486	25	
A	420	2510305	1.910	195	135	105	0,707	20	
A	520	2510306	2.275	232	170	140	1,080	20	
A	620	2510307	2.120	216	170	140	1,475	20	
A	720	2510308	2.010	205	180	150	1,910	15	
A	820	2510309	1.920	196	200	170	2,116	1	
B	900	2510460	1.264	129	200	160	2,570	1	
B	1000	2510461	882	90	200	160	2,780	1	