

## 00801.14 - Supporto orientabile 1M antracite



### Dati

Codice	00801.14
Famiglia	Apparecchi da parete / Sistemi / Antintrusione componenti non modulari
Descrizione	Supporto orientabile 1 modulo Eikon, Arké e Plana, antracite
Stato prodotto	3 - Prod. gestito
Q.tà minima ordine	1 NR
Marchio	VIMAR

## Disegni

### Vista ingombri

- [download .png](#)
- [download .dxf](#)

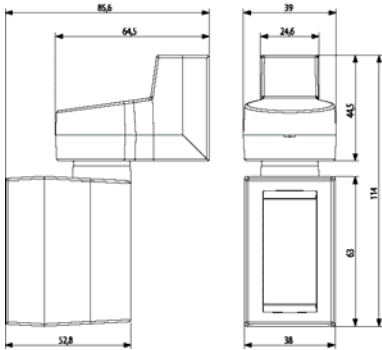

### Vista posteriore

- [download .png](#)
- [download .dxf](#)

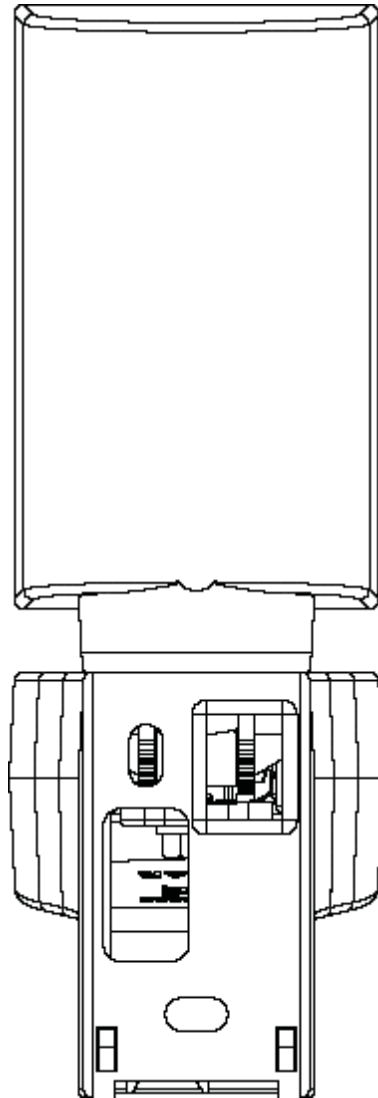

### Vista 3D

- [download .png](#)
- [download .dxf](#)

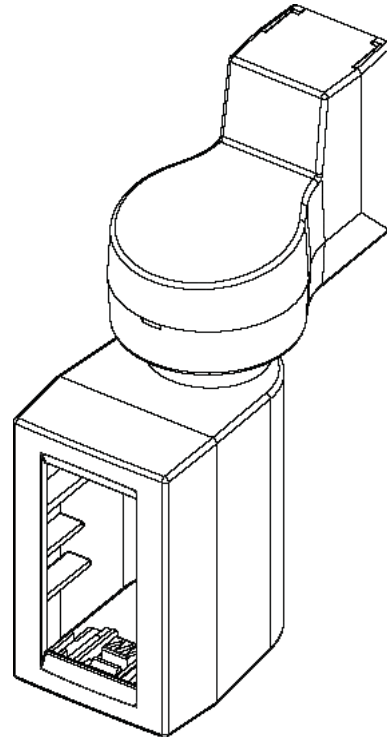

## Imballi



Codice: 8007352442467

Qtà: 1 NR

Dim.: 12,3x9,6x5,1cm

Peso: 86,4g